

Anatomy of a DxPedition: Crozet Islands



Tino Zottola, VE2GCE

April 17, 2023

Agenda

- Introduction
- Logistics
- Equipment
- Challenges
- Road to Success
- Conclusion

Introduction

Crozet Islands part of French Southern & Antarctic Lands (**TAAF***) 2585 km SE of South Africa

- Discovered on 24 January 1772 by **Marc-Joseph Marion du Fresne**
- Named after 2nd-in-command **Jules Crozet** who claimed archipelago for France

Island occupied by 35 scientists and support staff all year round

1 – First leg: 12 hr flight from Paris to Reunion Island

2 – Second Leg: 8 days by boat to Crozet Islands (Ile de la Possession)

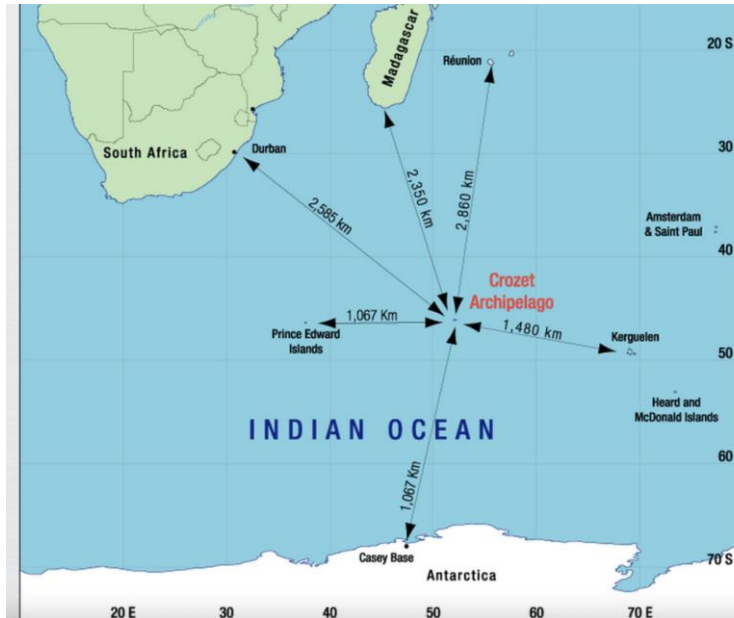

* TAAF - Terres Australes et Antarctiques Françaises

Logistics

- Last expedition 2009 by **Florentin Bard, F4DYW**, operated as FT5WQ
- Once in a lifetime opportunity, #3 DXCC on most wanted list (3/340)
- DXpedition estimated cost \$60,000+ USD
- Special permission required from TAAF prefect. Years spent navigating French bureaucracy
- Single operator → **Thierry Mazel, F6CUK** operating as FT8WW
- 1st three week operating window: Dec 25th, 2022 → Jan 14th, 2023
- 2nd three week operating window: Feb 10th, 2023 → Mar 3rd, 2023
- Radio silence for 5 hours per day mandated to avoid interference with ongoing scientific experiments
- Boat (**Marion DuFresne**) makes trip 4 times per year to Crozet Islands (enroute to other TAAF islands)
 - Thierry waited until March 25, 2023 for boat to Reunion Island
 - Boat must stop at other TAAF islands (i.e. Kerguelen and Amsterdam islands) before returning to Reunion
 - He arrives back in France in May

Rank	Prefix	Entity Name	Whitelisted?
1.	P5	DPRK (NORTH KOREA)	✓
2.	3Y/B	BOUVET ISLAND	✓
3.	FT5/W	CROZET ISLAND	✓
4.	BS7H	SCARBOROUGH REEF	✓
5.	CE0X	SAN FELIX ISLANDS	✓

Crozet Island Research Settlement



Garage

Chaud-Froid

Centrale électrique

CASERNE

Réserve Naturelle

Salle de sport

Coopérative

Infra (Casto)

Résidence

Déchetterie

Labos (Biomar)

Logements (Albatros)

HÔPITAL

VieCom

Logements (Francès)

Chambres froides

Logements (Azorelle)

Télécoms

Gérance Postale

Equipment

➔ Used shelter and power provided by permanent scientific mission

HF Equipment used:

- Pair of Kenwood TS-590 transceivers + 500 W ACOM 1010 amplifiers
- HF antennas taken down often during wind storms to avoid damage

HF Operation initially 30 and 20 meters, then only 20 meters and above

- Mostly FT8 MSHV mode (not F/H) and some CW
- Levy dipole (variation of G5RV) and vertical antenna
- Antenna choices dictated by TAAF
- Mode (FT8, CW) dictated by Thierry's desire to maximize contacts with modest stations not just best equipped stations using SSB

SSB via satellite QO-100 (@ 2.4 Ghz) (with no restrictions)

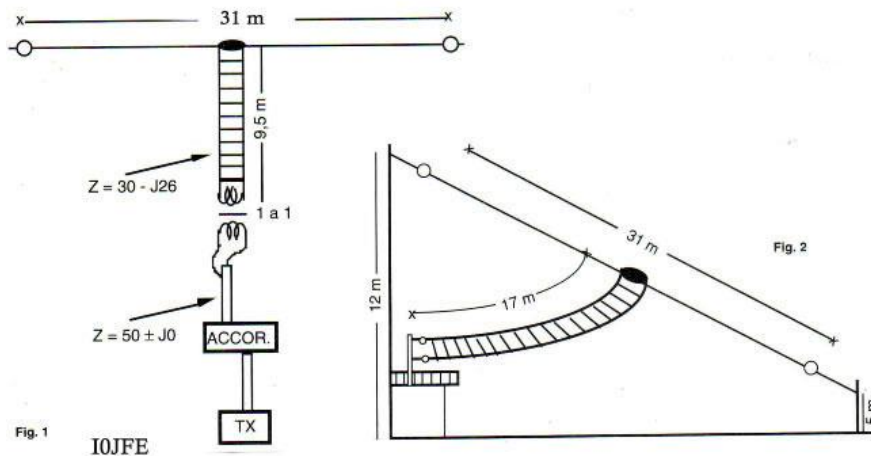

Challenges

1) Pirates

One or more stations were pretending to be FT8WW

- Quickly discovered by hams with beam antennas and reported on dxwatch.com
- Expedition organizers sent out regular tweets reporting pirates

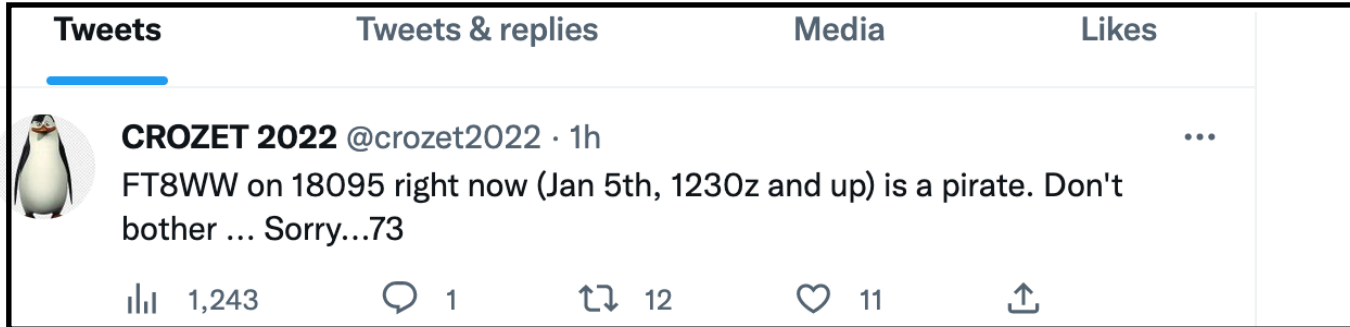

- Unfortunately several hams made contact with pirates and not the real FT8WW station
- Simplest way to verify legit contacts is via ClubLog.com or search log on dxnews.com



Your Log | **DXCC Charts** | **Satellite Charts** | **Timelines** | **Grid Squares** | **QSL Charts** | **Zone Charts** | **Log Inspector** | **Log Matching** | **League Tables**

Log Matching

Club Log will match QSOs where both parties have uploaded their log to Club Log, with a tolerance of ± 15 minutes. This can help you QSL contacts and to stay informed about log uploads that are relevant to your DXing progress.

Filter by mode: All modes CW Phone Data

Filter by band: All bands Filter by DXCC: CROZET ISLAND

All matches Bands Modes Slots DXCCs

Callsign: VE2GCE

Legend: New DXCC New band New mode New slot **Tip:** You can click on table headings to sort.

DX Call	Entity	QSO Date	Match Date	Band/Mode	Outcome
FT8WW	CROZET ISLAND	2023-01-01 22:09:45	2023-01-02 07:15:35	30M Data	DXCC 30M Data 30M Data

Challenges

2) Whiners and Complainers

Dxwatch.com (and other DX Clusters) very useful for reporting legitimate spots and pirate transmissions
But trolls often complaining pollute site with useless comments

Unfortunately there were many instances of people complaining and personally attacking Thierry

- Bulletin board is rarely seen by actual DX operators, only by hams hoping to make a rare DX contact
- Many asking DxPedition operator to switch to CW, SSB, another frequency or time slot
 - No one really cares if you are missing contact # 332 CW on your DXCC honor roll and need FT8WW on CW

de	dx	freq	obs	time
	 FT8WW	14085	Now even more confusion switching time slot	1720z 27 Dec
	 7Q7EMH	24915	[LoTW]	1718z 27 Dec
	 EA8CN	24900.9	[LoTW] [AF-004] cq cq	1713z 27 Dec
	 EA8CN	24901	[LoTW] [AF-004]	1713z 27 Dec
	 ZD7MY	21074	[AF-022] FT8 -03db CQ	1649z 27 Dec
	 FT8WW	14085	Get money back! 20k for what?	1644z 27 Dec
	 FT8WW	14085	WC3W "arching" ? whats that	1644z 27 Dec
	 FT8WW	14085	SQQ NOT FH, MSHV	1638z 27 Dec
	 CN8NY	28074	FT8	1634z 27 Dec
	 FT8WW	14085	WC3W arching on TX	1634z 27 Dec
	 7X3YOTA	21141.9	[LoTW]	1628z 27 Dec
	 FT8WW	14085	Ifyou can do better	1628z 27 Dec
	 FT8WW	14085	Go to Crozet yourself	1625z 27 Dec
	 FT8WW	14085	Why so negative?	1624z 27 Dec

Road to Success

3) Weak signal @ 16000 km

The key to successful Dx contacts is persistence, adaption and continuous experimentation

- Use PSK Reporter helps to see if you can reach the DX station (but not all DX stations have internet)
- Could not hear him via my 6BTV vertical and G5RV dipole @ 20 ft → only with 525 ft quad initially
- During mild weather, I took the opportunity to raise the height of my G5RV dipole to 55-60 ft
- My best reception was achieved with higher positioned G5RV

→ After 7 days of trying, successfully contacted FT8WW on Jan 1st, 2023

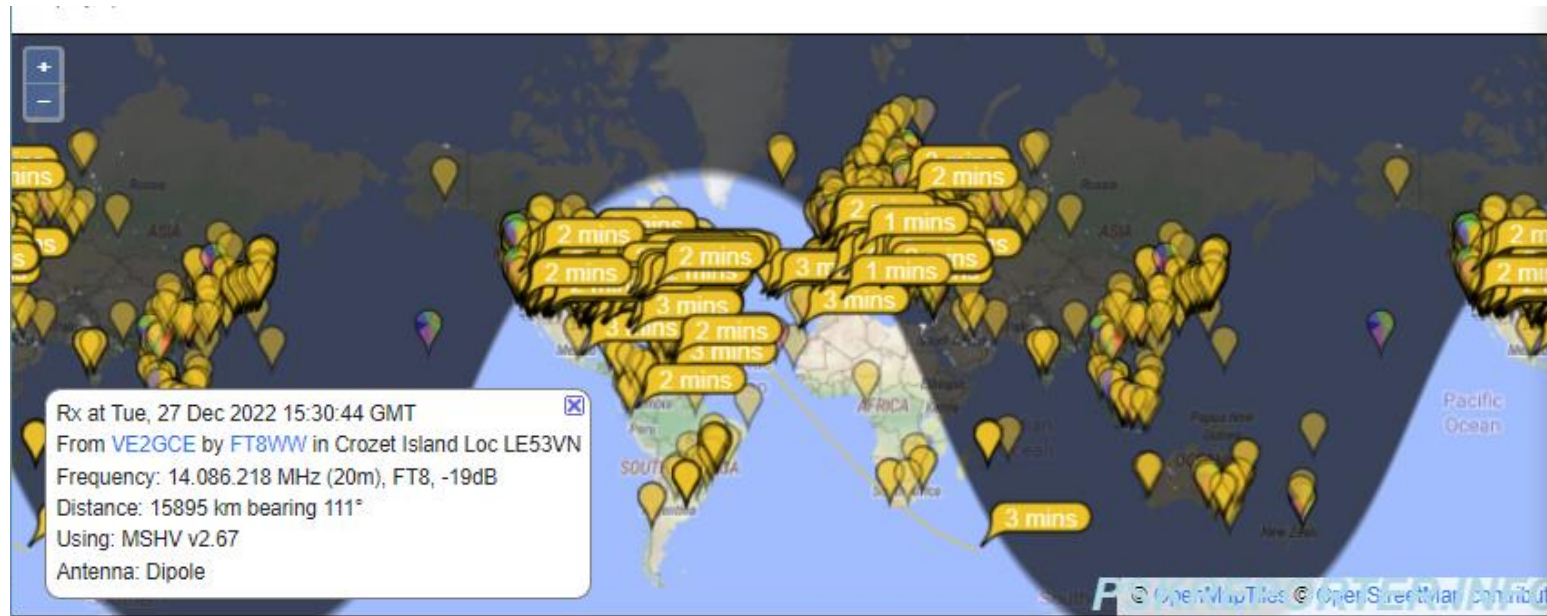

Conclusion

Tremendous effort in execution of DxPedition in desolate location

- Need to a superman to do one man DxPedition
- Bureaucratic hurdles of dealing with TAAF prefect, getting permission to operate on Crozet Islands
- Financing (\$60000+ UDS): Dx Clubs, ClubLog QSL requests, some donations and some personal funds
- Environmental challenges, equipment shipping, setup and fighting weather
- Time commitment: 2 x three wks operating slots + 21 wks away from home (in transit or waiting for boat)

Successful contact with DxPedition involved:

- Study all DxPedition details carefully → DXNews.com, ARRL.org, Dxwatch.com, and Twitter
- Check propagation conditions on <https://www.voacap.com/hf/>
- Secret to success → persistence

Questions ?



Thierry with local inhabitants of Crozet Islands



Even in Antarctica, the French eat well